

GENERAL NOTES

- DO NOT SCALE THIS DRAWING. WORK ONLY TO FIGURED DIMENSIONS.
- FOR ALL RELEVANT NOTES, REFER TO STRUCTURAL AND CIVIL ENGINEERING PERFORMANCE SPECIFICATION.
- ANY DISCREPANCIES ARE TO BE REPORTED TO PINNACLE CONSULTING ENGINEERS IMMEDIATELY.
- THIS DRAWING IS TO BE READ IN CONJUNCTION WITH ALL OTHER RELEVANT ENGINEERS, ARCHITECTS AND SUB-CONTRACTORS DRAWINGS AND DETAILS.

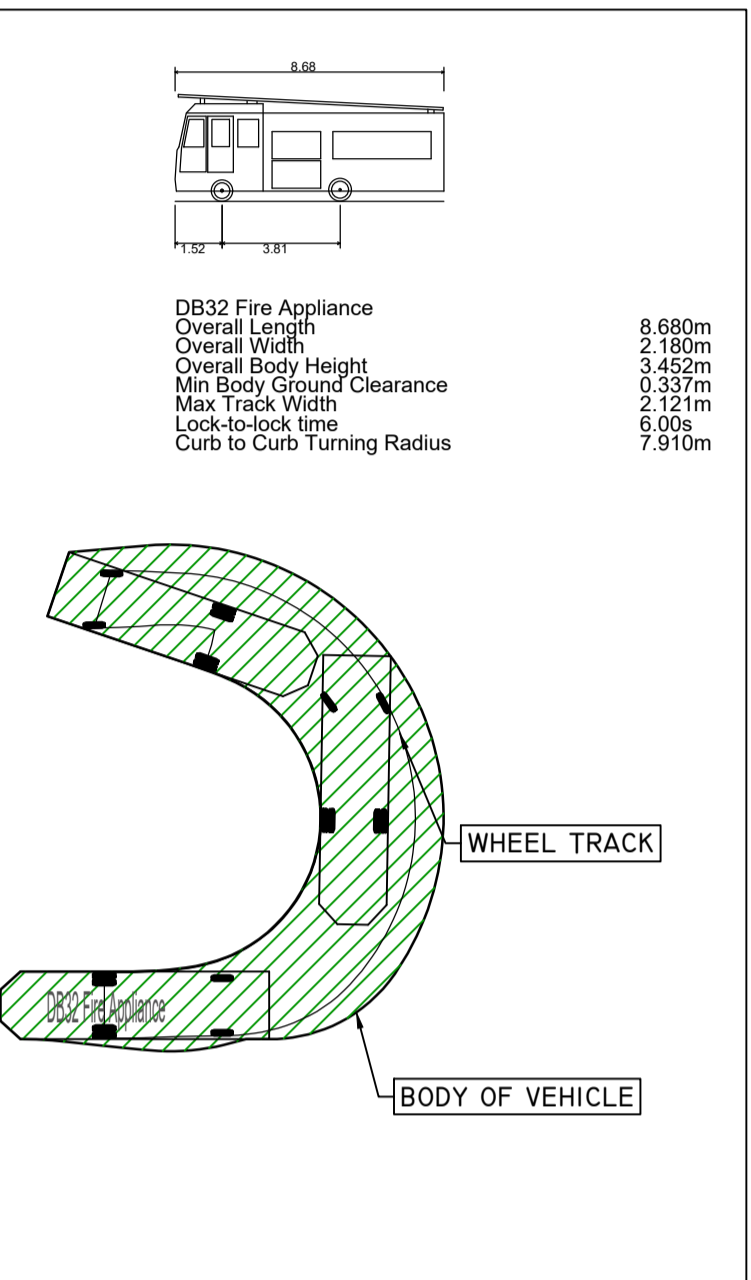

0 50MM ON A1 DWG. 50

REV	DESCRIPTION	BY	CHK	DATE

CLIENT
KELLAND HOMES LTD.
DURKAN ESTATES LTD.

PROJECT
LANDS AT BOHERBOY ROAD, SAGGART

DRAWING TITLE
AUTOTRACK LAYOUT - FIRE TENDER
SHEET 1 OF 3

PINNACLE
 CONSULTING ENGINEERS

GROSVENOR COURT,
 67A PATRICK STREET,
 DUN LAOGHAIRE,
 COUNTY DUBLIN
 IRELAND. TELEPHONE: +353 1231 1041
 WELWYN GARDEN CITY | NORWICH | LONDON | THE HAGUE

DRAWING STATUS			
SCALE	DATE	DRAWN BY	CHECKED
1:500	FEB'22	RK	RK
DRG NO.	REVISION		
P200107-PIN-XX-DR-D-0060-SI	P01		

COPYRIGHT PINNACLE

HEATH & SAFETY NOTE
 THIS DRAWING IS ISSUED FOR PLANNING ONLY AND SUBJECT TO DETAILED DESIGN.

VEHICLE MANOEUVRES (INCLUDING REVERSING) WITHIN DEVELOPMENT WHERE VEHICLES, PEDESTRIANS & OTHER VRUS WILL BE PRESENT. ALL MANOEUVRES TO BE DONE UNDER SUPERVISED CONDITIONS ONLY USING BANKS MAN.

RISK TO VULNERABLE ROAD USERS

HEATH & SAFETY NOTE
 TIGHTER JUNCTION RADII IN ACCORDANCE WITH SECTION 4.3.3 OF DMURS. THIS RESULTS IN LARGER VEHICLES CROSSING THE CENTRE LINE OF THE INTERSECTING STREET OR ROAD. SUCH MANOEUVRES ARE ACCEPTABLE WHEN TURNING INTO/OR BETWEEN LOCAL OR LIGHTLY TRAFFICKED LINK STREETS AS KEEPING VEHICLE SPEEDS LOW IS OF HIGHER PRIORITY.

RISK OFF RTC

DESIGN ISSUE
 AUTOTRACK ANALYSIS SHOWN FOR ILLUSTRATIVE PURPOSE. ACTUAL PERFORMANCE WILL BE VEHICLE AND/OR DRIVER SPECIFIC.

